

For Precast  
& Tilt-up  
Construction

## UNIVERSAL DRIP EDGE

**SAVE MONEY on your next project with VICTORY BEAR!**

Victory Bear is an innovative manufacturer of products for the tilt-up, precast, and cast-in-place industries. We offer the most complete line of precast and tilt-up profiles available, producing the cleanest and sharpest finishes in the industry. Victory Bear is a leader in revolutionary concrete designs--creating products that provide architects and contractors with unique options and unparalleled versatility.

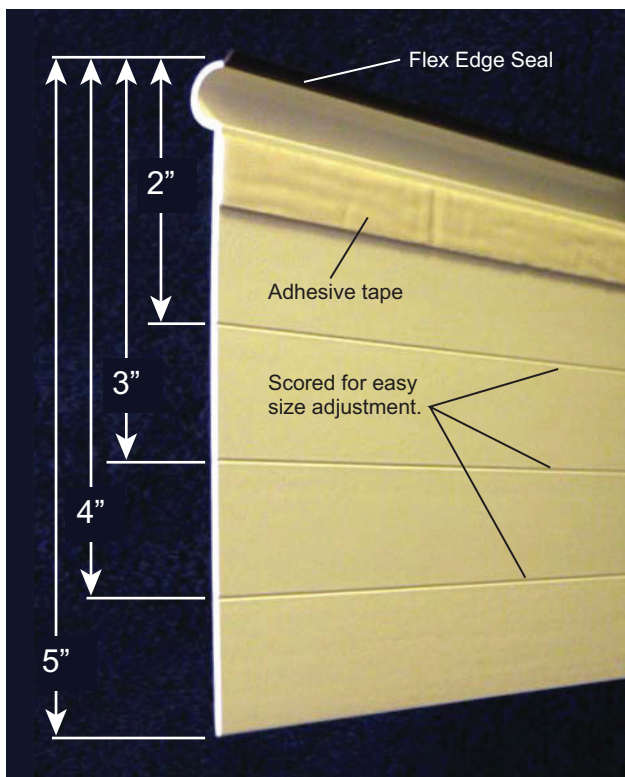

Victory Bear's new Universal Drip Edge is scored for easy size adjustment. These score lines give you the freedom to change the drip's depth from 5" to 4", 3", or 2". The adhesive tape and Flex Edge Seal ensure ease of installation and quality finish.

### Features & Benefits

Victory Bear's Universal Drip Edge uses a patented Flex Edge Seal and a PVC surface to provide a smooth and straight drip edge for doors, windows, and archways. It is scored to easily meet your size requirements, giving you maximum control and versatility.

- **New Improved Design!** – Victory Bear Universal Drip Edge is designed with rigid and flexible PVC for superior performance and value! The rigid PVC creates a superior finish, while the flexible PVC creates a tight seal against the form board, **greatly reducing the need for caulking in precast applications!**
- **Greater Versatility** – Universal Drip Edge is scored at 1" increments, easily allowing you to adjust the depth of the drip from 2 to 5 inches.

- **Patented "Flex Edge Seal"** – Our patented Flex Edge Seal fits tightly against the casting surface, preventing concrete seepage and creating sharp, crisp lines.
- **Easy Installation** – Simply remove the backing of the built-in adhesive tape and firmly press into place.
- **The Victory Bear System** – Use with Victory Bear single chamfers (not included) for the perfect chamfer/drip edge system.

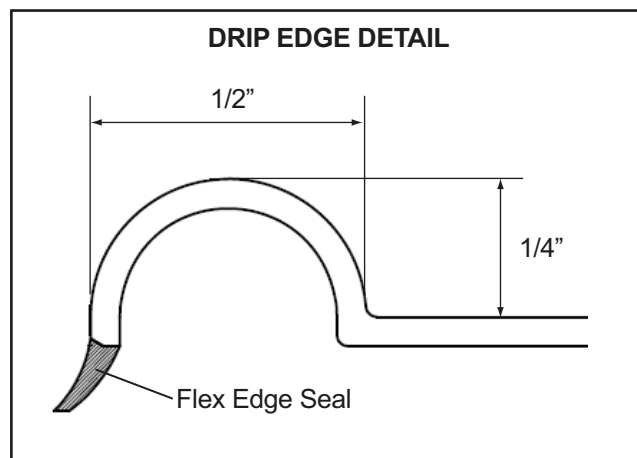

**A.L. Patterson, Inc.**  
300 Ben Fairless Drive  
Fairless Hills, PA 19030  
Ph: (800) 332-7090 / (215) 736-2030  
Fx: (215) 736-2652

www.Patterson-Online.com  
sales@alpatterson.com

## UNIVERSAL DRIP EDGE

For Precast  
& Tilt-up  
Construction



### Installation

- **Step 1** – Determine the desired depth of the drip edge. If placing at a depth of less than 5" from the outside wall, cut the appropriate score line with a utility knife, then break at the score line.

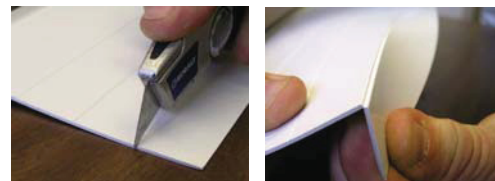

- **Step 2** – Peel away the adhesive tape's backing.



- **Step 3** – Using the bottom of the Universal Drip Edge piece as a guide against the casting surface, firmly press the adhesive into place onto the form board.

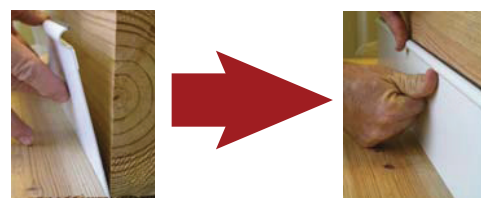

- **Step 4** – Set the Victory Bear Snap Single Chamfer into place by removing the backing from its adhesive tape and adhering it to the casting surface. While the chamfer is open, use its horizontal leg to hold the bottom of the Universal Drip Edge piece in place.

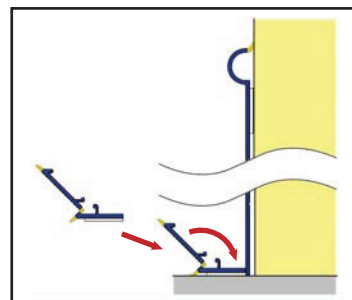

- **Step 5** – Close the Snap Single Chamfer and check to ensure its Flex Edge Seals are pressed firmly against the casting surface and the Universal Drip Edge. Make sure there are no gaps between the Flex Edge Seals and the contact surfaces.

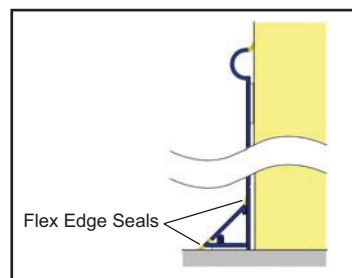

- **Step 6** – Caulk only the ends of the Universal Drip Edge, as well as any joints. It is **not** necessary to caulk along the Flex Edge Seals.

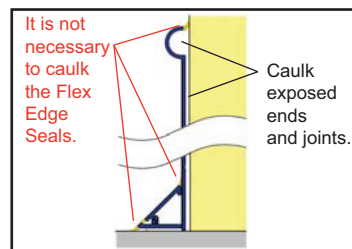

#### Specifications

Length: 8 ft.

Coefficient of Linear Expansion: 0.0132 inches per degree F

**Storage:** If re-using, remove all concrete residue from the plastic to prevent sticking on future pours. Materials should be stored out of direct sunlight to prevent long-term deterioration or color fading. Pieces can be stacked, but should be stored fully supported to keep them from warping.



**A.L. Patterson, Inc.**  
300 Ben Fairless Drive  
Fairless Hills, PA 19030  
Ph: (800) 332-7090 / (215) 736-2030  
Fx: (215) 736-2652

[www.Patterson-Online.com](http://www.Patterson-Online.com)  
[sales@alpatterson.com](mailto:sales@alpatterson.com)